

- Eight available core styles
- Extruded aluminum construction
- Core reinforcement is standard
- Size limitations are 6" x 2" minimum and 72" x 12" maximum for single piece
- Maximum 12" width for floor applications
- Sizes available in 1/2" increments
- Standard finishes available are white (WH) and mill (ML)
- Removable core
- See submittal WDLS09 for max loading

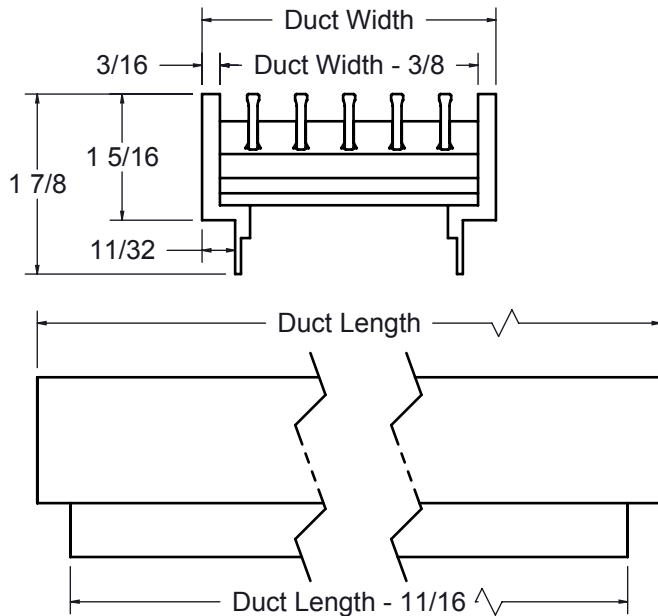

Finishes

- WH - White
- ML - Mill
- AP - Aluminum Paint
- OW - Off-White
- FB - Flat Black
- MP - Match Paint
- CA - Clear Anodized

Available Cores

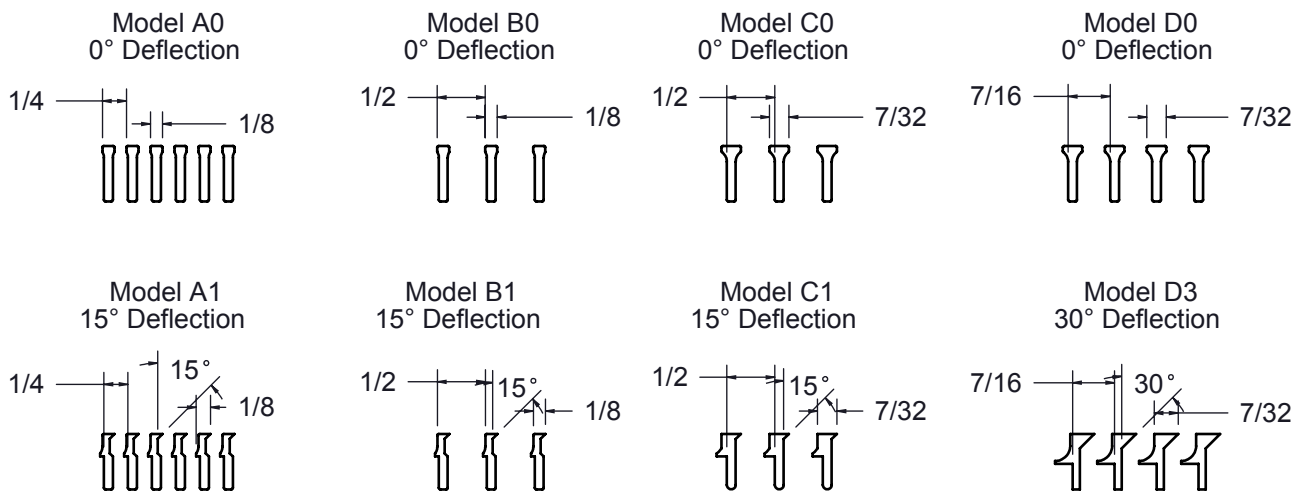

Dimensions in inches

Job: _____
 Location: _____
 Architect: _____
 Engineer: _____
 Contractor: _____

Tag: _____
 Submitted By: _____
 WDLS07 Rev: A (06/19)

WLFD
Linear Diffuser
Mounting Style 800, Heavy
Duty Frame without Flange
Floor Applications